

# SolidDrive SD1

SD1, SD1g, SD1sm, SD1 Desktop

## Sound Transducer

Technical Information for System Engineers



**SOUNDTUBE**  
ENTERTAINMENT

SD1, SD1sm



SD1g, SD1 Desktop



### Specifications: SD1, SD1g, SD1sm, SD1 Desktop Mounting hardware included

System Type	Direct drive, on-surface, or in-wall
Impedance (nominal) <sup>1</sup>	8 ohm
Sensitivity dB @ 2.83V/1M	70 · 75 dB <sup>10</sup>
Sensitivity dB @ 1W/1M <sup>2</sup>	73.5 dB <sup>10</sup>
Frequency Response (-3 dB) <sup>3</sup>	80 Hz · 10 kHz
Frequency Response (-10 dB) <sup>3</sup>	60 Hz · 15 kHz
Max. Program Power <sup>4</sup>	100 w <sup>11</sup>
Max. Continuous Power RMS <sup>5</sup>	30 w
Max. Power SPL @ 1 M <sup>6</sup>	88.5 dB
Coverage Angle (-6 dB @ 2 kHz)	120°
Coverage Angle (-6 dB @ 10 kHz)	120°
Transducer	SolidDrive SD1
Enclosure Material	Chrome plated aluminum
Grille	N/A
Inputs	Wire lead with screw connector block
Colors	Chrome plated aluminum
Height	2.02 in / 51.3 mm
Diameter	2.30 in / 58.4 mm
Weight	1.2 lb / 0.5 kg
Shipping Weight	2.0 lb / 0.9 kg
<b>Accessories</b>	
Optional	Wood EQ, Drywall EQ, Glass EQ, Pre-Construction Bracket
Packaging	1 per box
Regulatory - CE	Approved

#### Notes:

<sup>1</sup> Impedance listed per IEC 60268-5

<sup>2</sup> 1w1m sensitivity determined using nominal impedance

<sup>3</sup> Frequency response measured in half or full space as dictated by speaker mounting configuration

<sup>4</sup> Max program power is 3 dB above max continuous power

<sup>5</sup> Continuous power rating EIA-426-B test

<sup>6</sup> Max output based on max continuous power

<sup>7</sup> Max useable SPL based on testing by NWA Labs

<sup>10</sup> Equivalent to conventional in-wall @ 4m

<sup>11</sup> With 100 Hz 12 dB / oct high pass filter

<sup>12</sup> Since radiation is from a large surface, the decrease in SPL with distance is significantly less than conventional in-wall speaker (-6 dB/doubling), thus causing an apparently higher sensitivity at listening distances.

## Preliminary Technical Data

### Key Features

- Proprietary dual-voice coil technology in a durable, sealed aluminum enclosure delivering higher power handling and sensitivity across multiple substrates.
- Symmetrically opposed neodymium magnets convert audio signals into acoustical energy for any ridged surface including glass, drywall, ceramic and wood.
- Hidden planer-source audio technology evenly distributes uniform acoustic energy throughout the listening space.
- Proprietary behind-surface mounting technologies ensure maximum visual appeal.
- 88.8 Max SPL (drywall) and 120° dispersion pattern across the upper registers of the frequency spectrum.
- Drywall (SD1) included accessories: self-leveling, constant tension pre-construction bracket to ensure proper alignment & wall contact.
- Glass (SD1g) included accessories: high-bond, double-sided VBH adhesive disk.
- Wood, laminate & composite (SD1sm) included accessories: direct-screw aluminum mounting base.
- Desktop included accessories: mini amplifier, 15 Volt power supply, passive EQ module, 4 international outlet adaptors, connector cables and a durable carrying case.
- Optional accessories include passive EQ modules for drywall, glass or wood; 20 Watt metal junction box for 25, 70.7 & 100 Volt applications.
- For extended frequency response, couple SolidDrives with SW7 or SW8 subwoofers.
- Patent pending technology and friction-free engineering deliver an industry-leading 7-year warranty for all SolidDrive models.

### Description

The SolidDrive utilizes patent-pending dual-voice coil technology in an aluminum enclosure to transfer acoustic energy to any substrate. Symmetrically opposed neodymium magnets and specifically engineered mounting hardware results in hidden planar-source acoustics. The result is acoustical uniformity throughout the listening space.



### Frequency Response – Typical Dry-wall SolidDrive Response

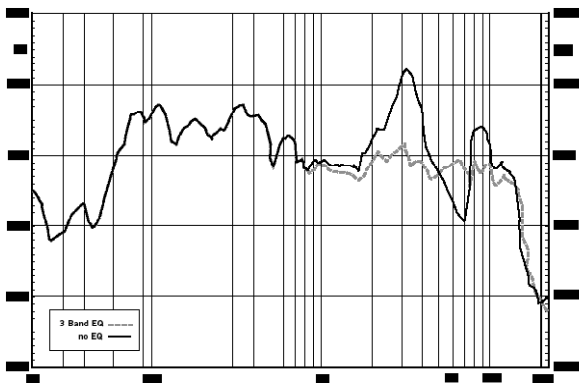

### Frequency Response – Typical Wood Table-Top SolidDrive Response

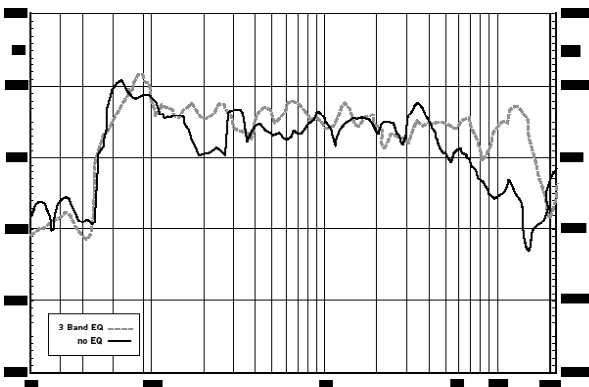

### Frequency Response – Typical Glass SolidDrive Response

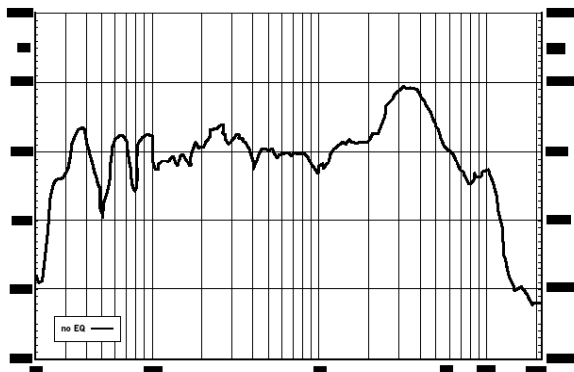

### Directivity Index (DI) - Off Axis Response On 4x8' Drywall Panel Outdoors in 4' Direction Referenced to 0deg @2m

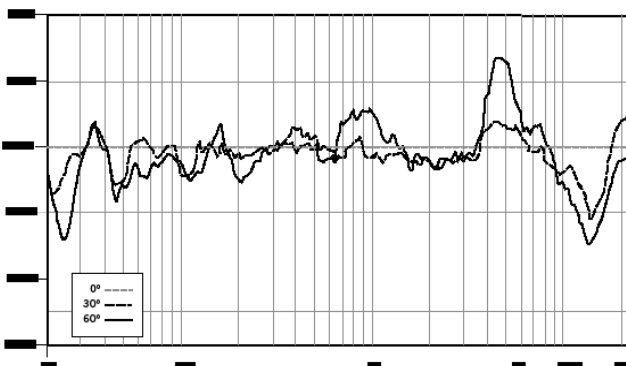

## Commercial Applications

SolidDrive technology and patented mounting mechanisms allow for audiophile quality sound through any ridged substrate including drywall, glass, wood, laminate & ceramic. Applications include retail, restaurant, boardroom, tradeshow, presentations and more. With planar-source technology, the location of the SolidDrive on the surface has no impact on the quality or uniformity of the delivered sound field. For bass response down to 25 Hz, SolidDrive SW7 (7 inch) and SW8 (8 inch) subwoofers can be included. For 25, 70.7 or 100 Volt applications, consider the 20 Watt junction box accessory

## Solid Drive EQ Modules

Because surface material plays a critical role in the system's sound performance, SoundTube engineers have pioneered substrate-specific passive EQ modules for drywall, glass and wood. Each module is designed to eliminate excessive energy at specific frequencies (dominant resonant modes) relevant to those substrates. Simple and effective, the EQ modules use notch filters to correct frequency response peaks.

## Patented SoundTube Technologies

SoundTube Entertainment and the MSE Audio Group constantly develop new technologies which enhance audio product performance. SoundTube Entertainment innovations are protected by multiple U.S. & international patents, which explicitly cover SoundTube dome, enclosure and dispersion technologies. The MSE Audio Group actively defends its patents in order to protect SoundTube resellers and end-users.

## Technical Data and Specification Tools

### Technical Data

SoundTube Entertainment strives to provide complete and effective technical information and data to dealers, engineers and designers. All data are available from SoundTube Entertainment or at [www.soundtube.com](http://www.soundtube.com) and includes EASE™ Data – 3-D polar plots and SoundTubeSPEC™ – Proprietary SoundTube speaker placement software.



### Independent Data Acquisition & Verification

All data for SoundTube speakers is independently collected from and verified by NWAALabs ([www.nwaalabs.com](http://www.nwaalabs.com)) their proprietary MACH testing system. All data is collected and analysed according to ASTM, ISO and AES standards using EASERA, TEF and MLSSA. Full balloon data including both phase and magnitude is compiled into a variety of formats including EASE 4.x, GLL and CLF.

### Architectural Specifications

The loudspeaker shall consist of full-

range transducer constructed of neodymium magnets in an aluminum enclosure.

Performance specifications are dependent upon substrate type and size. Typical production unit specifications are as follows: Useable frequency response shall extend from 60 Hz – 15 kHz (-10 dB, 1/2 space, no external equalization). Measured sensitivity (2.83 Volt input, 1 meter) shall be at least 70.0 dB (drywall tested). The speaker shall have a nominal impedance of 8 Ohms and rated power capacity shall be at least 30 Watts RMS. The max. SPL shall be 88.5 dB (drywall tested).

Installation for the SolidDrive shall include galvanized steel pre-construction

bracket for drywall, high-bond, double-sided VBH adhesive for glass or direct-screw mounting plates for surface-mount applications including wood. The desktop mounting kit includes mini amplifier, 15 Volt power supply, passive EQ module, 4 international outlet adaptors, connector cables and a durable carrying case.

### SoundTube Entertainment

6430 North Business Park Loop  
Park City, Utah 84098  
Phone 435.647.9555  
Fax 435.647.9666  
Toll Free 800.647.TUBE  
[www.soundtube.com](http://www.soundtube.com)

**All SoundTube products come with a 5-year limited warranty.**

#### Dry-Wall Passive

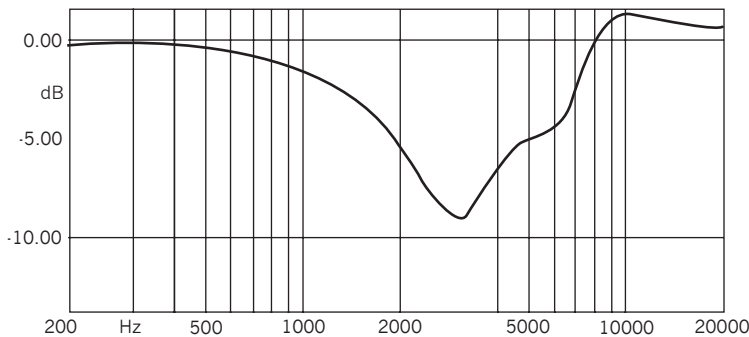

#### Glass Passive

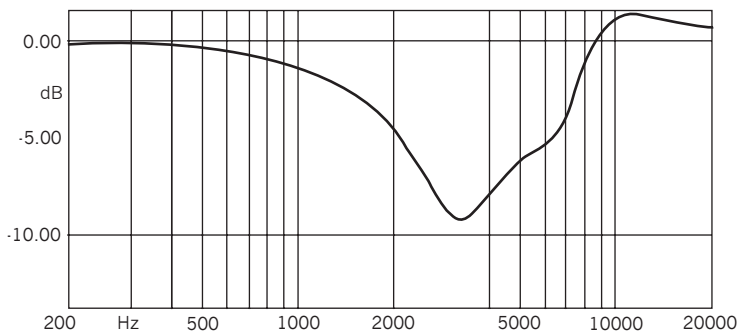

#### Desktop Passive

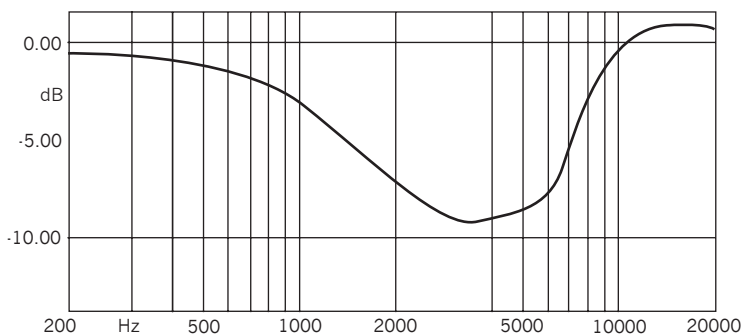

# SolidDrive SD1

SD1, SD1g, SD1sm, SD1 Desktop

## Sound Transducer

Technical Information for System Engineers



**SOUNDTUBE**  
ENTERTAINMENT

### Mechanical Drawings

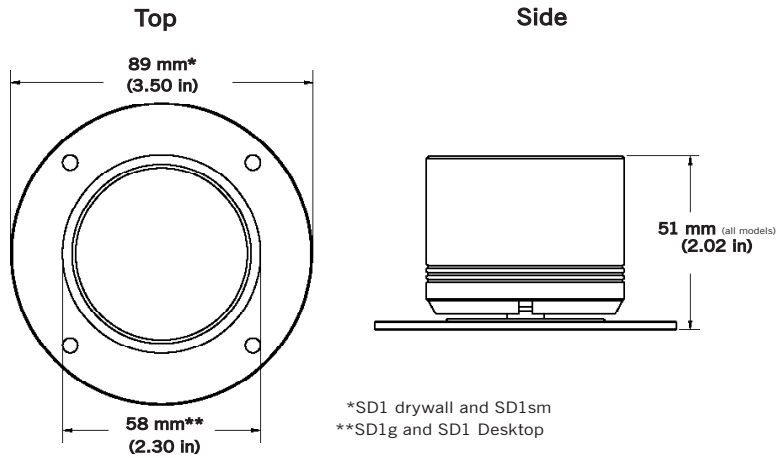

### Mounting Options

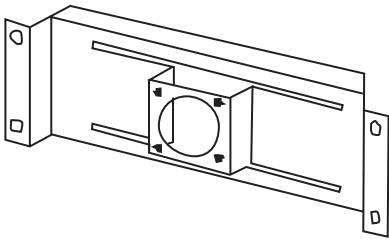

**In-wall mount**  
included with SD1

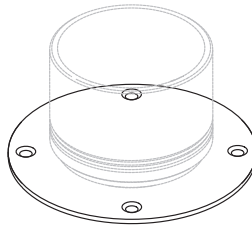

**Surface mount** - mounts screws from back  
included with SD1sm

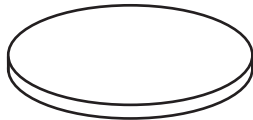

**Double sided VHB Silicone pad**  
included with SD1g

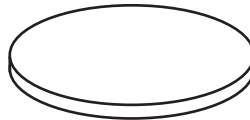

**Silicone pad**  
included with SD1 Desktop

SoundTube Entertainment manufactures a complete line of speakers for:  
**Open-Ceiling • In-Ceiling • Surface-Mount • Outdoor • Sound-Focusing**

All SoundTube products are designed and engineered in the USA.